

COPY RIGHT & CONFIDENTIAL

This document is the exclusive property of SHRIDHAN INDIA and contains confidential information. This document or its contents shall not be used, reproduced or disclosed in whole or in part, without prior written permission of SHRIDHAN INDIA. This document and all its copies shall be returned to SHRIDHAN INDIA on demand

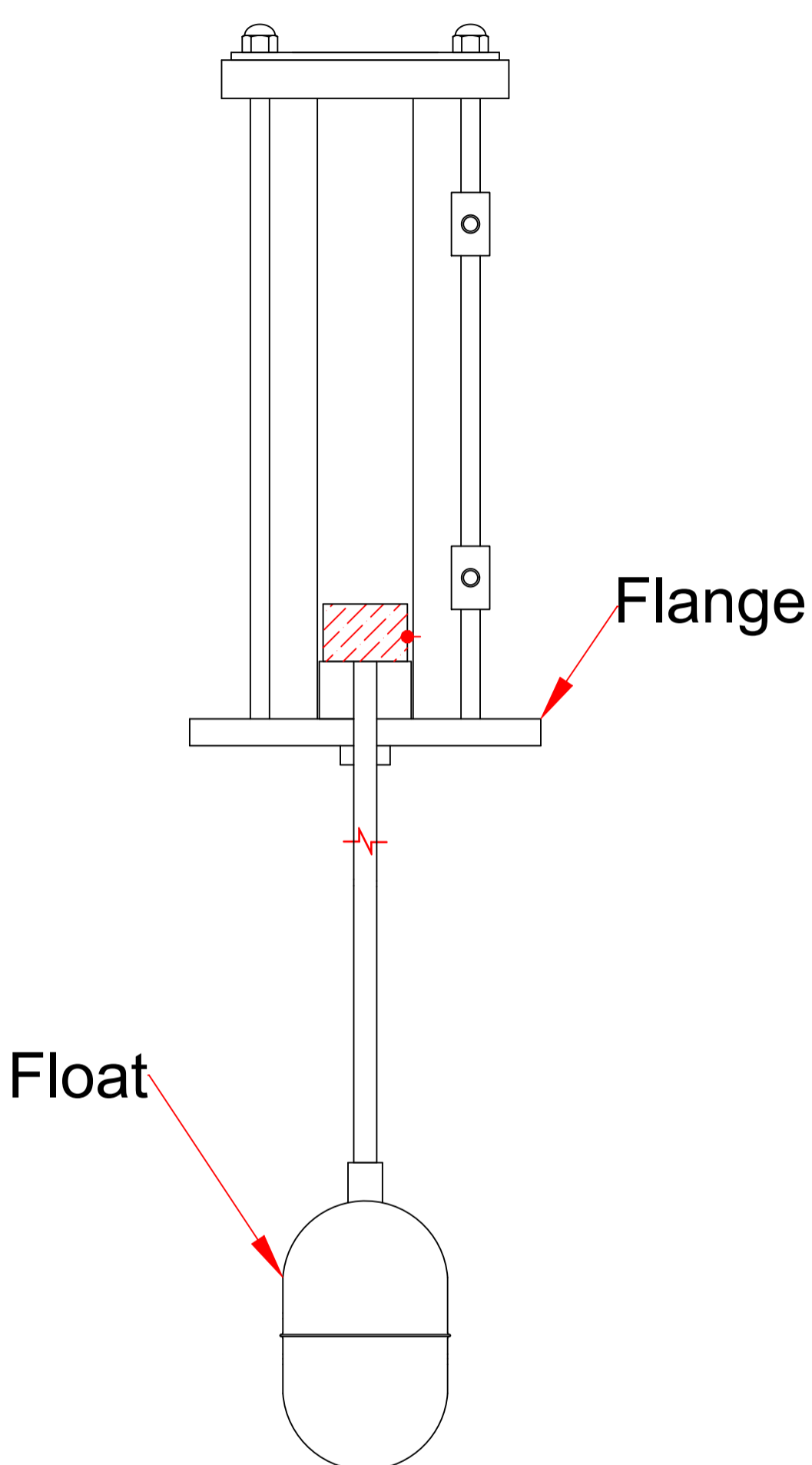

Float		
Sl No.	Size	Material
1	Ø45	SS 304
2	Ø57	SS 304
3	Ø89	SS 304

Flange	
Sl No.	Type
1	85x85 Square Flange 105 PCD
2	Ø75x65 PCD
3	92x52 Rectangular
4	With Breather Assembly

NOTE:
For any other variants contact factory.

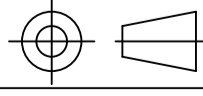
R0					
Rev	Description	Date	Drawn	Checked	Approved
Customer Name :					
End User:					
Cust Ref :		Drawing No. :	Rev No.	Projection :	
SO No. :					
Project:		All Dimensions in mm			
Scale :NTS		Title & Model No. Sight Level Indicator			