

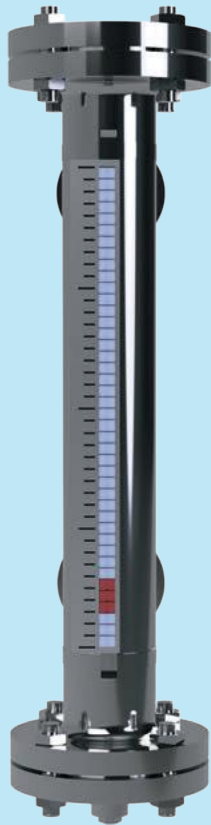

**MAGNETIC LEVEL
INDICATORS**



ISO - 9001-14001-45001 Certified



ATEX 2014/34/EU



Conformité Européenne



ABS - Type Approved Product



Pressure Equipment Directive
2014/68/EU



CIMFR / PESO / CCOE



Safety Integrity Level - 2

INDEX

1. MAGNETIC LEVEL INDICATORS – MLI	3
1.1 CONSTRUCTION AND OPERATION	3
1.2 FEATURES	3
2. SPECIFICATIONS	4
2.1 ACCESSORIES	4
3. TYPICAL STYLES OF A MAGNETIC LEVEL INDICATOR	5
3.1 ORDERING INFORMATION FOR MAGNETIC LEVEL INDICATORS	6
4. ORDERING INFORMATION FOR MAGNETOSTRICTIVE LEVEL TRANSMITTERS	8
4.1 ORDERING INFORMATION FOR MAGNETOSTRICTIVE LEVEL TRANSMITTERS SIL 2 & IEC CERTIFIED	9
5. APPLICATION CUSTOMIZED VERSIONS	10
5.1 MLI WITH THERMAL INSULATION / MLI WITH STEAM TRACING & THERMAL INSULATION	10
5.2 MLI WITH CRYOGENIC INSULATION / INTERCONNECTED MLI'S	10
6. MAGNETO SERIES / MLI WITH TRANSMITTER & SWITCHES	11
6.1 MLI WITH SWITCHES / MLI WITH TRANSMITTER	11
6.2 TOP MOUNTED MLI WITH TRANSMITTER/ TOP MOUNTED MLI WITHOUT TRANSMITTER	11
7. ACCUMULATOR APPLICATION VERSIONS (PISTON ACCUMULATOR FOR HYDRAULIC APPLICATIONS)	12

1 MAGNETIC LEVEL INDICATORS – MLI

Magnetic Level Indicators are used in applications requiring continuous measurement, indication and control of liquid levels. The design relies on the hydrostatic pressure principle to display tank level in a side mounted measuring chamber. A float, containing a ring magnet, rises and falls with the liquid level in the bypass chamber. This approach allows an all metal construction which eliminates the breakage and leakage problems frequently experienced with glass tube designs. Transmission, Visual indication or Switching may be achieved by mounting magnetically sensitive devices on the exterior of the bypass chamber. These devices are activated by the magnet inside the float.

1.1 CONSTRUCTION AND OPERATION

MAGNETIC FLAPPER TYPE

A communicating bypass chamber is flanged to the side of a vessel, and as the liquid level in the tank rises or falls, a float with a built-in magnetic system inside the chamber rises or falls with it. (Refer Fig.01). The chamber is completely sealed so that the only moving part of the apparatus in contact with the liquid is the float itself. On the dry side of the chamber is the magnetic flapper display, a column of magnetic flappers which are white on one side and red on the other. The rollers are made from stainless steel with a distance of 10 mm between their axes. As the float moves up or down the bunched field of the permanent magnet mounted in its top section pulls the rollers through a rotation of 180°, thus changing their color. As the float rises the rollers are turned from white to red, and as the float falls, they are changed back to white again. This means that at any given time the amount of liquid in the tank is constantly represented by a red column without any external power supply.

MAGNETIC SHUTTLE TYPE

This is an economy type Indicator with equally effective performance. The indicator consists of an encased follower / magnet inside a glass tube. The follower magnet is coupled with the float magnet inside the cage and move along with the float to indicate the correct liquid level (Refer Fig.02). The frame of this indicator is made of Aluminium.

1.2 FEATURES

- Circular magnet system effective from all sides.
- Upto 250 bar pressure.
- Temperatures upto 400 °C.
- Remote transmission capability.
- Permanent local indication with out external power supply.
- Switch options available.
- Industrial ruggedness.

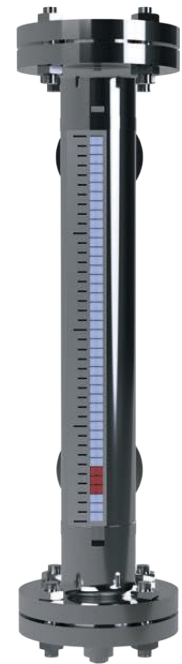

Magnetic Level Indicator

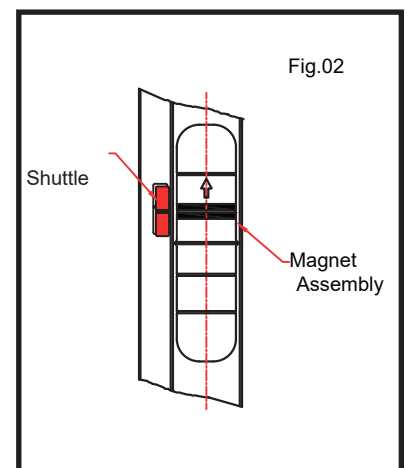
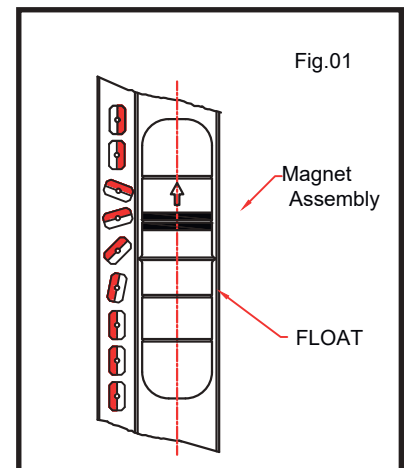

2 SPECIFICATIONS

Installation	Side/ Top
Range (C-C Distance)	300- 5000mm (Magnetic Flappers Display) 300- 3000mm (Magnetic Shuttle Display)
Float Chamber	2" and above in SS304 / 316 / 316L / Hastelloy / Inconel, Titanium, PP, PVDF, PTFE, other non-ferritic materials
Process Connection	For Side Mounting- 15NB and above - other Flanges as per BS / ANSI / DIN or ½" / ¾" / 1" BSP/ NPT (M/F) Threaded For Top Mounting - 50NB and above - Flanged to BS/ANSI/DIN
Float Material	316 / 316L / Hastelloy / Inconel, Titanium, PP, PVDF, PTFE, other non-ferritic materials
Level Indication Display	a) Bi-Color Magnetic Flappers - SS304/SS316 up to 400°C b) Magnetic Shuttle - Aluminum up to 200°C
Still Well (For Top Mounted only)	SS304 / SS316 / SS316L / PP / Alloys / PVDF
Calibrated Scale	Stainless steel
Vent and Drain Valve	Sizes from ½" and above
Vent and Drain Plug	Sizes from ½" and above
Max. Temperature	70 °C (PP) / 100 °C (PVDF) 400 °C (Metallic)
Max. Operating Pressure	Upto 250 bar (Metallic) / Upto 5 bar (PP / PVDF / PTFE)
Min. Liquid Sp.Gravity	0.4 - Side mounted, 0.6 - Top mounted

Note: For lower SG and higher pressure ratings - Contact factory

2.1 ACCESSORIES

- Reed Switches - SPDT and DPDT
- Micro Switches - SPDT and DPDT
- Reed Chain Transmitters or Magnetostrictive Level Transmitters
- Thermal Insulation - for high temperature services
- Cryogenic Insulation - for cryogenic services
- Anti-frost Extensions - for cold temperature services and where visible extensions are required
- Tracing - Steam / Electrical - for viscous services
- Magnetic Particle Traps - for eliminating magnetic particles from process
- Isolation Valves (for process connection) - for easy maintenance of instrument

3 TYPICAL STYLES OF A MAGNETIC LEVEL INDICATOR: SHRIDAN - O

S

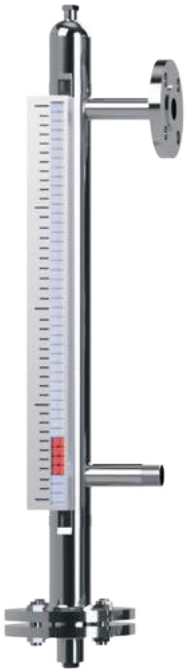

H



R



I



D

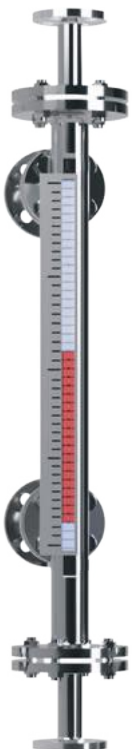

A



N

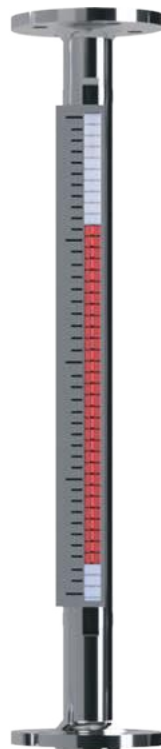

O

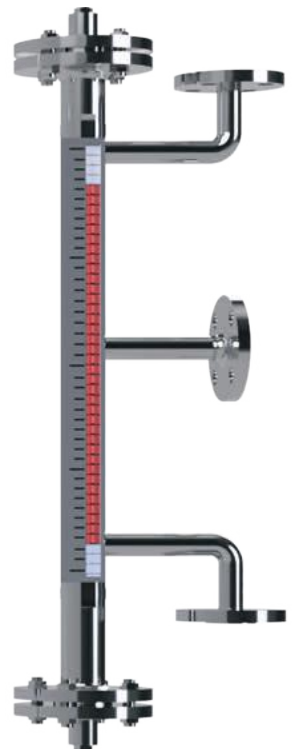

3.1 ORDERING INFORMATION FOR MAGNETIC LEVEL INDICATORS

SPECIFY PART NO.

MLI

1	2	3	4	5	6	7	8	9	10	11
<input type="checkbox"/>	<input type="checkbox"/>	<input type="checkbox"/>	<input type="checkbox"/>	<input type="checkbox"/>	<input type="checkbox"/>	<input type="checkbox"/>	<input type="checkbox"/>	<input type="checkbox"/>	<input type="checkbox"/>	<input type="checkbox"/>

1	STYLE
S	Side-Side (Flange / Thread)
H	Side-Side w/ Top Flanged (Flange / Thread)
R	Top Flange and Side Bottom
I	Interface with intermediate connection
D	PTFE Lined
A	Top Mounting
N	Top and Bottom
O	Others

2	MATERIAL OF CONSTRUCTION
A	304 SS
B	316 SS
C	316L SS
D	316 / 316L SS (Dual Certified)
E	Titanium
F	Hastelloy C276
G	Inconel 625
H	Inconel 825
I	PVDF / Kynar
J	PP
O	Others

3	APPLICATION
L	Total Level
I	Interface Level
F	Flashing ¹
O	Others

4	FLOAT MATERIAL
A	316 / 316L SS
B	Titanium
C	Hastelloy
D	Inconel
E	PVDF / Kynar
F	PP
O	Others

5	INDICATION TYPE
A	Rotating Flappers (Red / White)
B	Shuttle
C	Hermetically Sealed Flappers
D	Broad Indicator
E	Custom Color Flappers ²
O	Others

² in consultation with factory

6	CHAMBER SIZE		
1	2" / DN 50	A	Sch. 10
2	2½" / DN 65	B	Sch. 40/STD.
3	3" / DN 80 ¹	C	Sch. 80/XS
4	4" / DN 100	D	Sch. 160
O	Others	O	Others

¹ for flashing applications choose 3" chamber size

7	PROCESS CONNECTION		
Flanged			
1	½" / DN 15	A	150# / PN16
2	¾" / DN20	B	300# / PN40
3	1" / DN 25	C	600# / PN64
4	1½" / DN 40	D	900# / PN100
5	2" / DN 50	E	1500# / PN160
6	3" / DN 80	F	2500# / PN250

Threaded			
7	½" / DN 15	G	NPT
8	¾" / DN20	H	BSP
9	1" / DN 25	O	Others
O	Others		

3.1 ORDERING INFORMATION FOR MAGNETIC LEVEL INDICATORS

SPECIFY PART NO.

MLI

1	2	3	4	5	6	7	8	9	10	11
<input type="checkbox"/>	<input type="checkbox"/>	<input type="checkbox"/>	<input type="checkbox"/>	<input type="checkbox"/>	<input type="checkbox"/>	<input type="checkbox"/>	<input type="checkbox"/>	<input type="checkbox"/>	<input type="checkbox"/>	<input type="checkbox"/>

8 VENT CONNECTION			
Flanged / Plugged / Valves			
1	1/2" / DN 15	A	150# / PN16
2	3/4" / DN20	B	300# / PN40
3	1" / DN 25	C	600# / PN64
4	1 1/2" / DN 40	D	900# / PN100
5	2" / DN 50	E	1500# / PN160
		F	2500# / PN250
		G	NPT Plug
		H	BSP Plug
		I	Threaded Valve
		J	SW Valve
		K	SW Valve w/ Flange ³
		L	Flanged Valve ³
0	NONE	N	NONE
		O	Others

10 OPTIONS / ACCESSORIES	
NN	None
SW	Switches for MLI
RX	REED Chain Level Transmitter
MX	Magnetostrictive Level Transmitter
IN	Thermal Insulation Jacket
CY	Cryogenic Insulation with anti-frost ext.
FR	Anti-frost extension
HT	Tracing (Electrical / Steam)
IV	Isolation Valves
MP	Magnetic Particle Traps
XX	Multiple options (as specified on TDS)
OO	Others

11 Area Classification	
0	Non-Hazardous
1	Hazardous

³ in case of SW Valve w/ Flange OR Flanged valves, rating of flanges shall be as per process / instrument connection

9 DRAIN CONNECTION			
Flanged / Plugged / Valves			
1	1/2" / DN 15	A	150# / PN16
2	3/4" / DN20	B	300# / PN40
3	1" / DN 25	C	600# / PN64
4	1 1/2" / DN 40	D	900# / PN100
5	2" / DN 50	E	1500# / PN160
		F	2500# / PN250
		G	NPT Plug
		H	BSP Plug
		I	Threaded Valve
		J	SW Valve
		K	SW Valve w/ Flange ⁴
		L	Flanged Valve ⁴
0	NONE	N	NONE
		O	Others

⁴ in case of SW Valve w/ Flange OR Flanged valves, rating of flanges shall be as per process / instrument connection

4 ORDERING INFORMATION FOR MAGNETOSTRICTIVE LEVEL TRANSMITTERS

SPECIFY PART NO.

MLT **1** **2** **3** **4** **5** **6** **7**

MLT

1	TYPE	CODE
	Transmitter + Display	B

2	PROCESS CONNECTION	CODE
	Without process connection for sliding sleeve	U

3	HOUSING	CODE
	Aluminium (ATEX and IECEx)	5
	Plastic	6
	Stainless Steel (ATEX)	7

4	CODE	PROBE LENGTH	CODE
	0	0 m 0.0	0
	1	1 m 0.1	1
	2	2 m 0.2	2
	3	3 m 0.3	3
	4	4 m 0.4	4
	5	5 m 0.5	5
		0.6 6	
		0.7 7	
		0.8 8	
		0.9 9	

5	OUTPUT / RESOLUTION	CODE
	4-20 mA + HART / 0.1mm	3
	4-20 mA + HART / 1mm	4
	4-20mA/0.1mm / Ex ia	5
	4-20mA/1mm / Ex ia	6
	4-20 mA + HART / 0.1mm / Ex ia	7
	4-20 mA + HART / 1mm / Ex ia	8
	4-20mA / 0.1mm / Ex d	A
	4-20mA + HART / 0.1mm / Ex d	B
	4-20mA / 0.1mm / Ex d + Ex ia	C
	4-20mA+HART / 0.1mm / Ex d + Ex ia	D
	4-20mA + HART/ 0.1mm / XP Zone 1/ NPT ½" / Dual Compartment	E
	4-20mA / 0.1mm / XP Zone 1 / NPT ½" / Dual Compartment	F

HOUSING POSITION	
Single Compartment	Dual Compartment

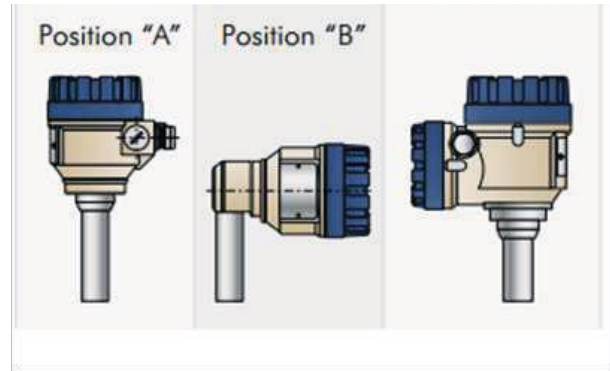

HOUSING POSITION	CODE
Top	A
Side	B
Dual Compartment	C

OTHER ACCESSORIES

TYPE	DESCRIPTION
SAP-300-0	Graphic plug In display module
SAT-304-0	HART-USB modem
SAK-305-2	HART-USB / RS485 modem
SAK-305-6	HART-USB / RS485 modem / Ex-ia

Position B is the standard position for transmitter mounting on MLI

4.1 ORDERING INFORMATION FOR MAGNETOSTRICTIVE LEVEL TRANSMITTERS SIL 2 & IEC CERTIFIED

1	2	3	4	5	6	7	8	9	10	11	12	13	14	15	16	17	18	19	20	21	22
L	P	C																			
a			b	c	d	e	f	g	h	i	j	k	l	m	n	o					p

A	SENSOR MODEL
L P C	Magnetostrictive Level Transmitter

B	OUTPUT
M	Modbus®
3	1 Loop with HART® and SIL2
6	1 Loop with HART

C	HOUSING TYPE
D	Single cavity with display
E	Dual cavity with display
L	SS single cavity with display

D	ELECTRONICS
3	90° bend housing top left
4	90° bend housing top right
5	90° bend housing bottom left
6	90° bend housing bottom right
7	Top mount
8	Bottom mount

E	SENSOR PIPE
B	5/8" OD pipe
R	1/2" OD pipe
Y	10mm OD pipe

F	MATERIALS OF CONSTRUCTION (WETTED PARTS)
1	316L stainless steel

Note Contact factory for other materials

G	PROCESS CONNECTION TYPE
X	None

H	PROCESS CONNECTION SIZE
X	None

I	NUMBER OF DT'S (DIGITAL THERMOMETER)
X	None

J	DIGITAL THERMOMETER PLACEMENT
X	None

K	NOTIFIED BODY		
B	IINMETRO	K	KC
C	CEC (FEC)	N	NEPSI
E	ATEX	p	CCOE
F	NEC (FM)	T	CML/TIIS
I	IEC	X	None

I	PROTECTION METHOD
F	Explosion Proof / Flame Proof *
I	IS
X	NO approval

* Only with Housing Type D, E, or L

M	GAS GROUP
A	Group A **
B	Group B
C	Group C
D	Group D
3	IIC ***
4	IIB+H2
X	None

** Group A not available with C=CEC (FMC) notice body and F=Flameproof/Explosion Proof protection method
*** IIC is only available with intrinsically safe approval

N	UNIT OF MEASURE
U	US customary - Inches
M	Metric - Millimeters

O	LENGTH (NO DECIMAL SPACES)
X X X X X	305...365mm (code as 0305 to 03658)
X X X X X	12...144 inch (code as 01200 to 14400)

P	SPECIAL
R	Reverse Measurement (select with electronic mount)
S	Standard Product

5 APPLICATION CUSTOMIZED VERSIONS

5.1 MLI WITH THERMAL INSULATION / MLI WITH STEAM TRACING AND THERMAL INSULATION

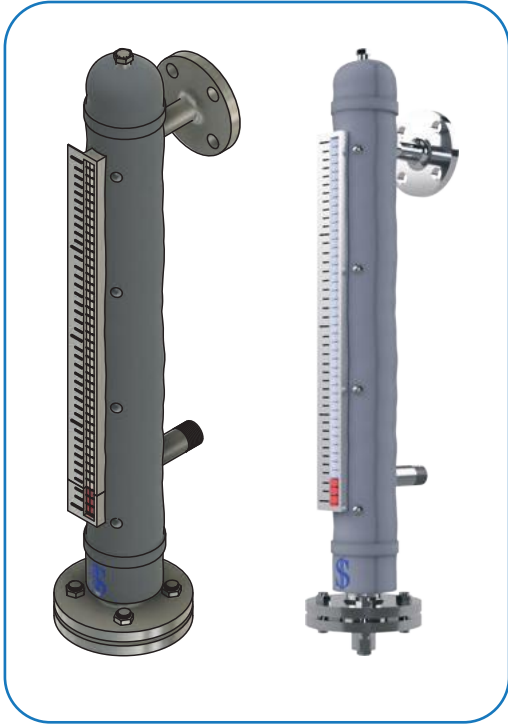

5.2 MLI WITH CRYOGENIC INSULATION / INTERCONNECTED MLI'S

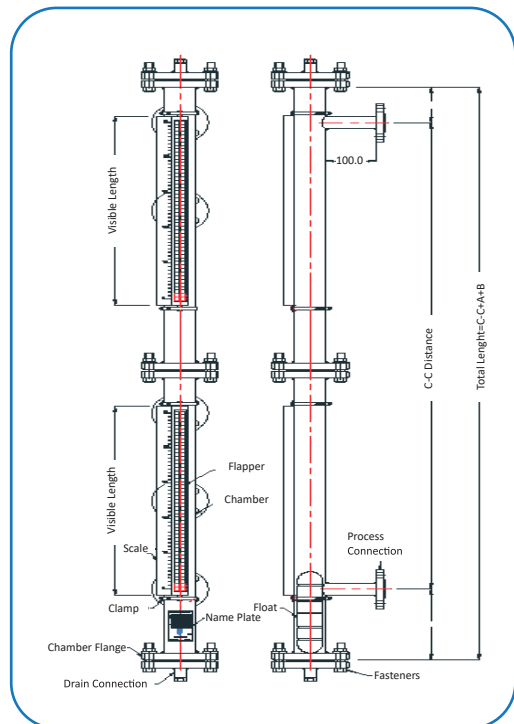
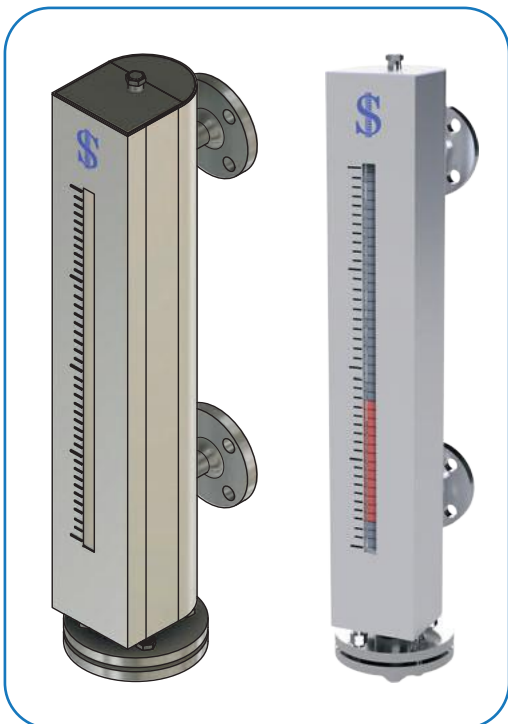

6 MAGNETO SERIES / MLI WITH TRANSMITTER & SWITCHES

6.1 MLI WITH SWITCHES / MLI WITH TRANSMITTER

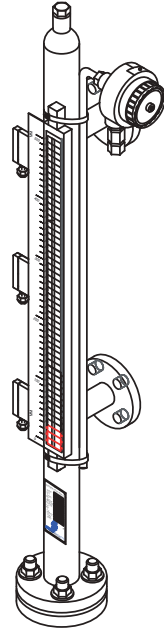
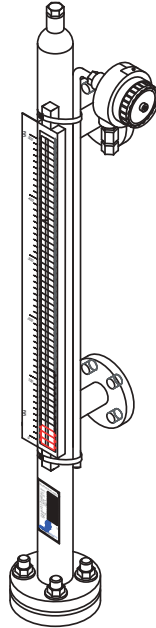
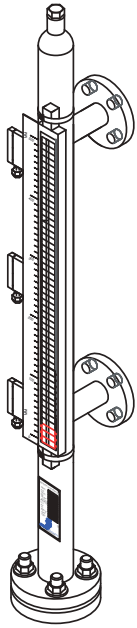

6.2 TOP MOUNTED MLI WITH TRANSMITTER / TOP MOUNTED MLI WITHOUT TRANSMITTER

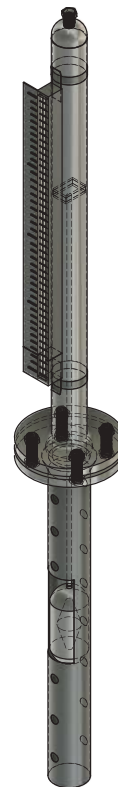
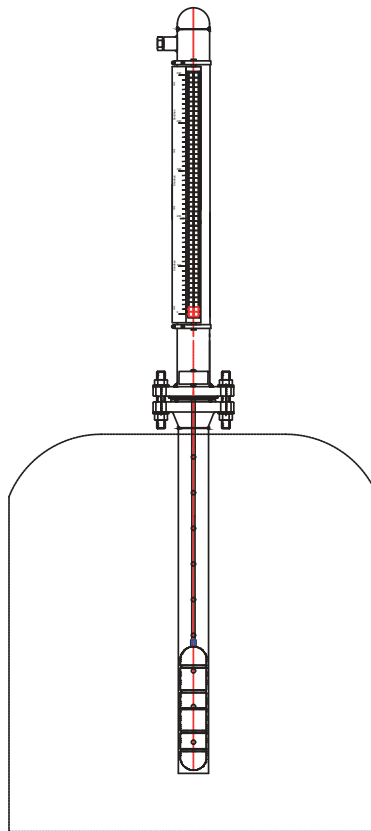
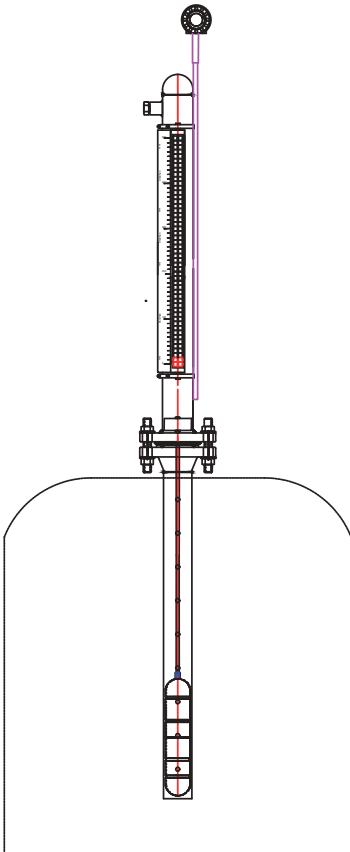

7 ACCUMULATOR APPLICATION VERSIONS (PISTON ACCUMULATOR FOR HYDRAULIC INDUSTRIES)

Piston accumulators have an outer cylinder tube, end caps, a piston element, and sealing system. The cylinder holds fluid pressure and guides the piston, which forms the separating element between gas and fluid. Charging the gas side forces the piston against the end cover at the fluid end. As system pressure exceeds the minimum operating level for the accumulator, the piston moves and compresses gas in the cylinder. Bi-colored Flapper indicators are provided for this design to indicate the level of the fluid inside the system. These flapper indicators operate according to the magnetic piston movement provided inside the Accumulator assembly. If continuous transmission is required, A Reed chain level transmitter is provided. which also operates as per the movement of piston inside the Assembly giving accurate output of the fluid level.

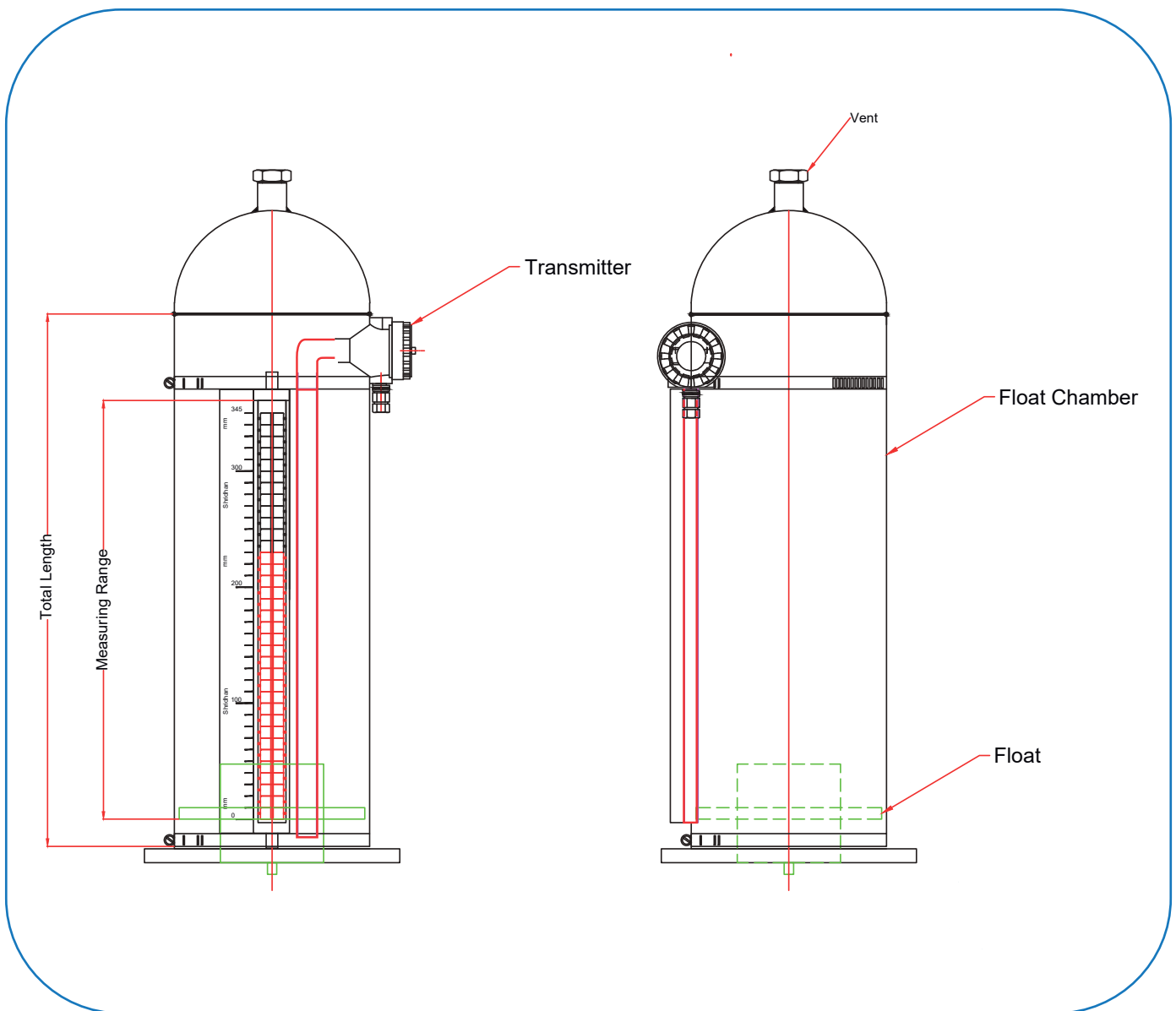



Head office and Manufacturing - 1

SHRIDHAN Automation Pvt. Ltd.
#B-54, KSSIDC Industrial Estate,
Kumbalgotu, Mysore Road,
Bangalore-560074. India.
+91-80-28437847, +91 80 - 28437848
info@shridhan.com

Manufacturing - 2

SHRIDHAN Automation Pvt. Ltd.
#D-13 KIADB Industrial Area,
Kumbalgotu, Mysore Road,
Bangalore-560074. India.
+91-80-28437847, +91 80 - 28437848
info@shridhan.com

Middle East

ORBIT Automation FZE
#R4-40 A, PO Box - 122828,
SAIF Zone, Sharjah, UAE.

A 100% Subsidiary of
SHRIDHAN Automation Pvt. Ltd., India.
Ph:+97155 - 9347963,+97155 - 1883375
me@shridhan.com

